

ETHERNET

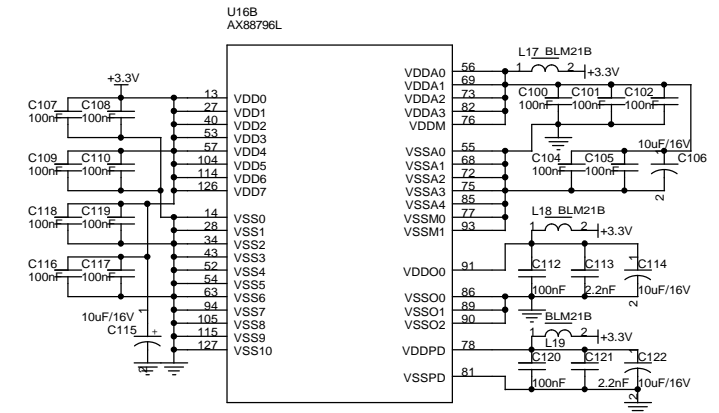
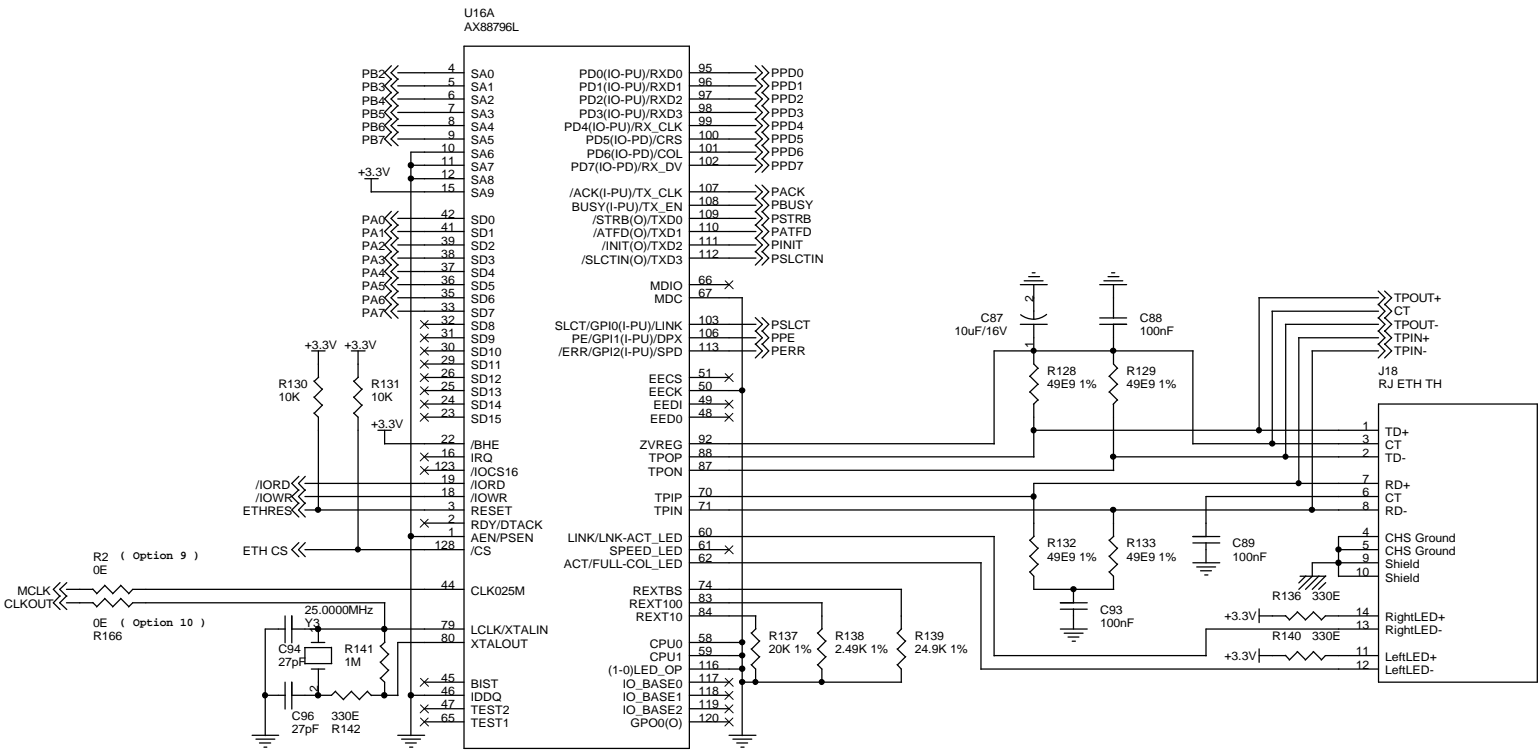
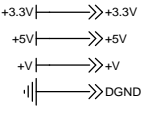

X-GRAPH (a DELGEN trademark) 241, route de Longwy L-1941 Luxembourg Design by Rudi De Laet			
XG5000 Product Family			
Size	CAGE Code	DWG NO	Rev
A3		XG5000-R7	1
Tuesday, May 24, 2011		Scale	Sheet 1 of 7

EXPANSION HEADERS

J1
ANALOG & SLAVE HEADER

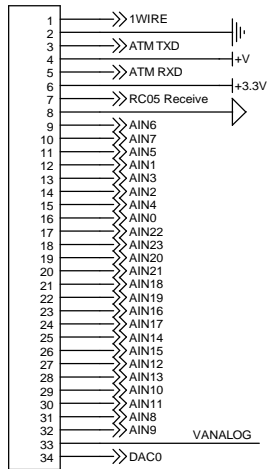

(24-pin header 1..24 installed if
FFC ATS is installed on J38 = T56A)

J2
RABBIT SERIAL IO EXPANSION

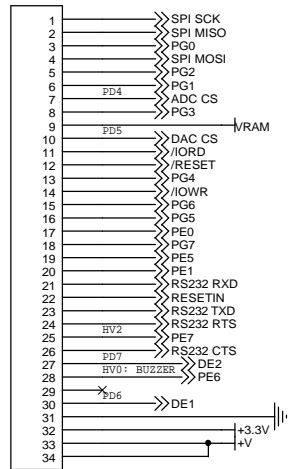

J3
MACH & LCD IO EXPANSION

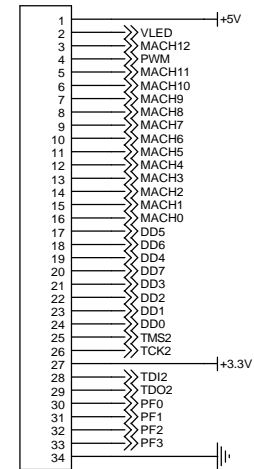

(2x5 installed on pin 25..34)
(Option 8: 34-pin header)

J4
RABBIT & ASIX IO EXPANSION

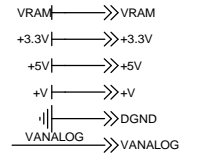
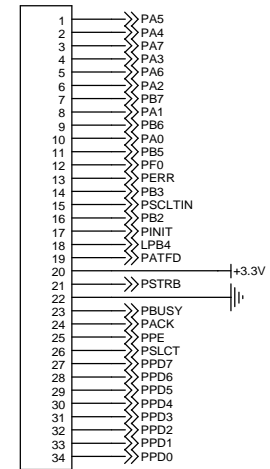

J21
BUFFERED IO HEADER

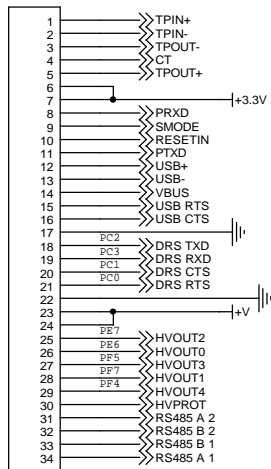

X-GRAPH (a DELGEN trademark) 241, route de Longwy L-1941 Luxembourg Design by Rudi De Laet			
XG5000 Product Family			
Size A3	CAGE Code	DWG NO XG5000-R7	Rev 1
Tuesday, May 24, 2011	Scale	Sheet 2 of 7	

LCD CONTROLLER

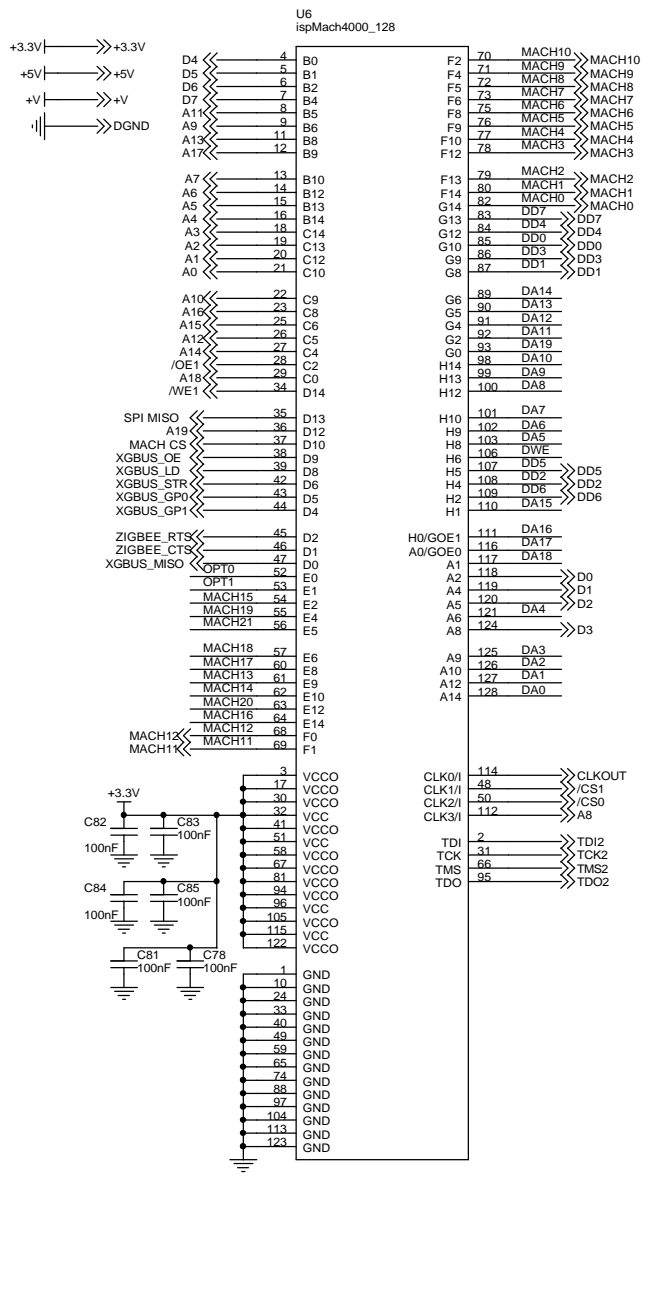

VIDEO MEMORY

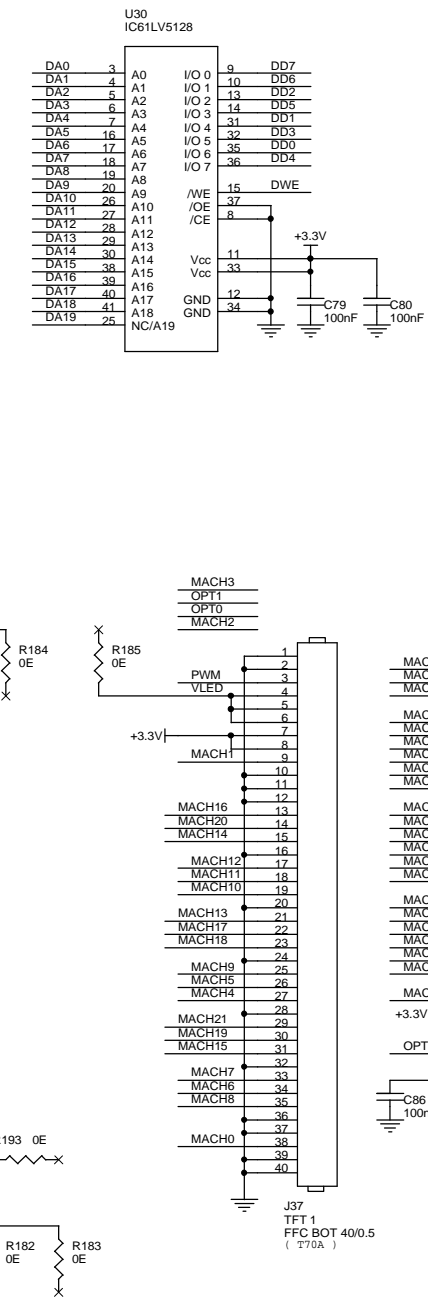

BACKLIGHT

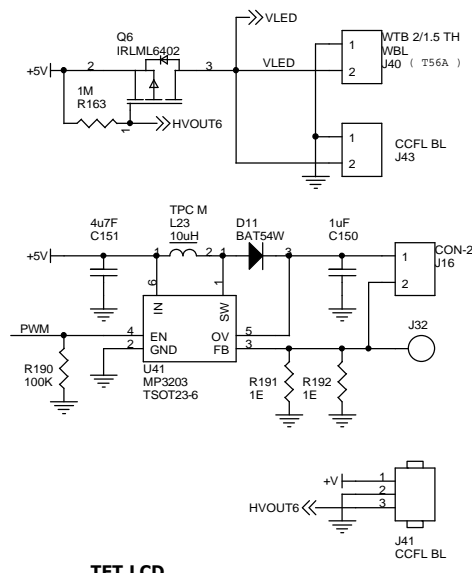

B/W LCD

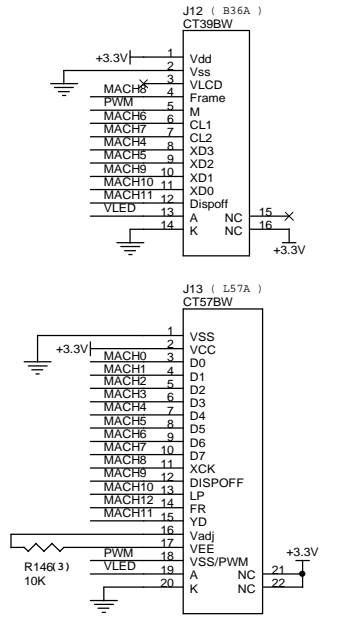

TFT LCD

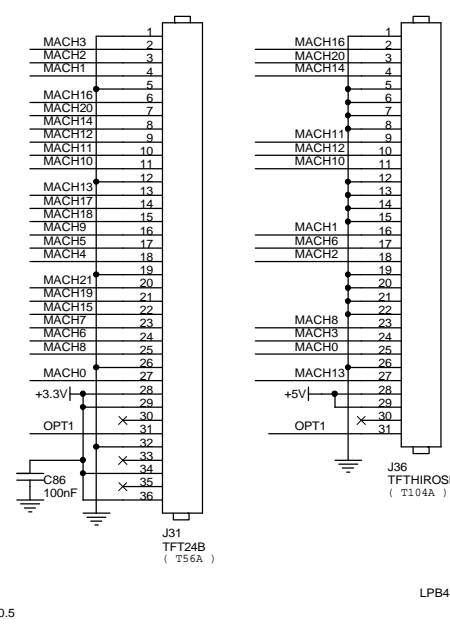

CSTN LCD

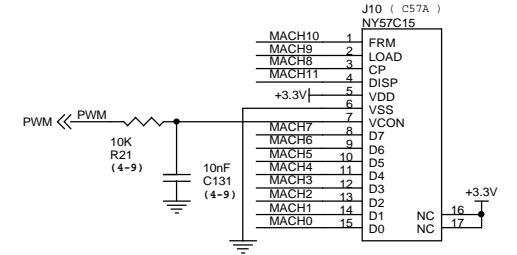

CHARACTER LCD

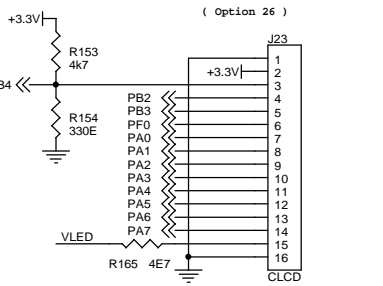

(1) Option on Standard Module (2) Installed on Development Kit (9) XG5000B36 (3.6" B/W QVGA LCD) (3) XG5000L57 (5.7" Blue/W QVGA LCD) (4) XG5000C57 (5.7" CSTN QVGA LCD) (5) XG5000Txx (all TFT LCD - 256 color) (6) XG5000Txx (QVGA TFT LCD - 16M color) (7) CCFL Backlight (8) White-Led Backlight		X-GRAPH (a DELGEN trademark) 241, route de Longwy L-1941 Luxembourg Design by Rudi De Laet	
XG5000 Product Family			
Size	A3	CAGE Code	DWG NO XG5000-R7
Scale		Sheet	3 of 7

Tuesday, May 24, 2011

POWER SUPPLY

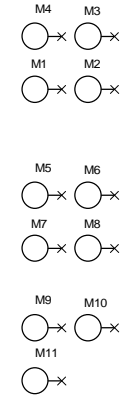
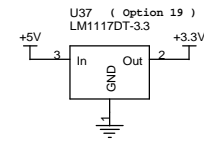
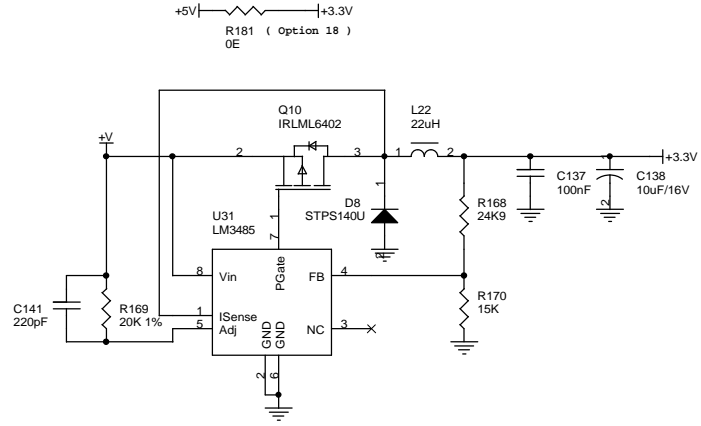
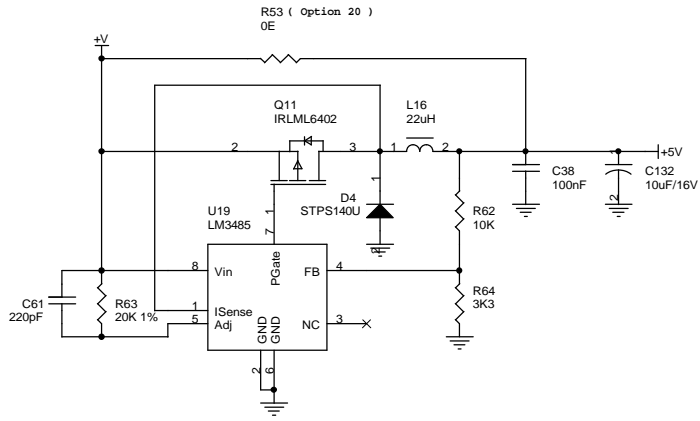
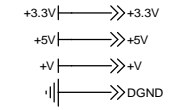
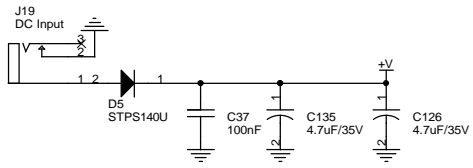

X-GRAPH (a DELGEN trademark) 241, route de Longwy L-1941 Luxembourg Design by Rudi De Laet			
XG5000 Product Family			
Size A3	CAGE Code	DWG NO XG5000-R7	Rev 1
Tuesday, May 24, 2011	Scale	Sheet 4	of 7

RABBIT 3000A

MEMORY

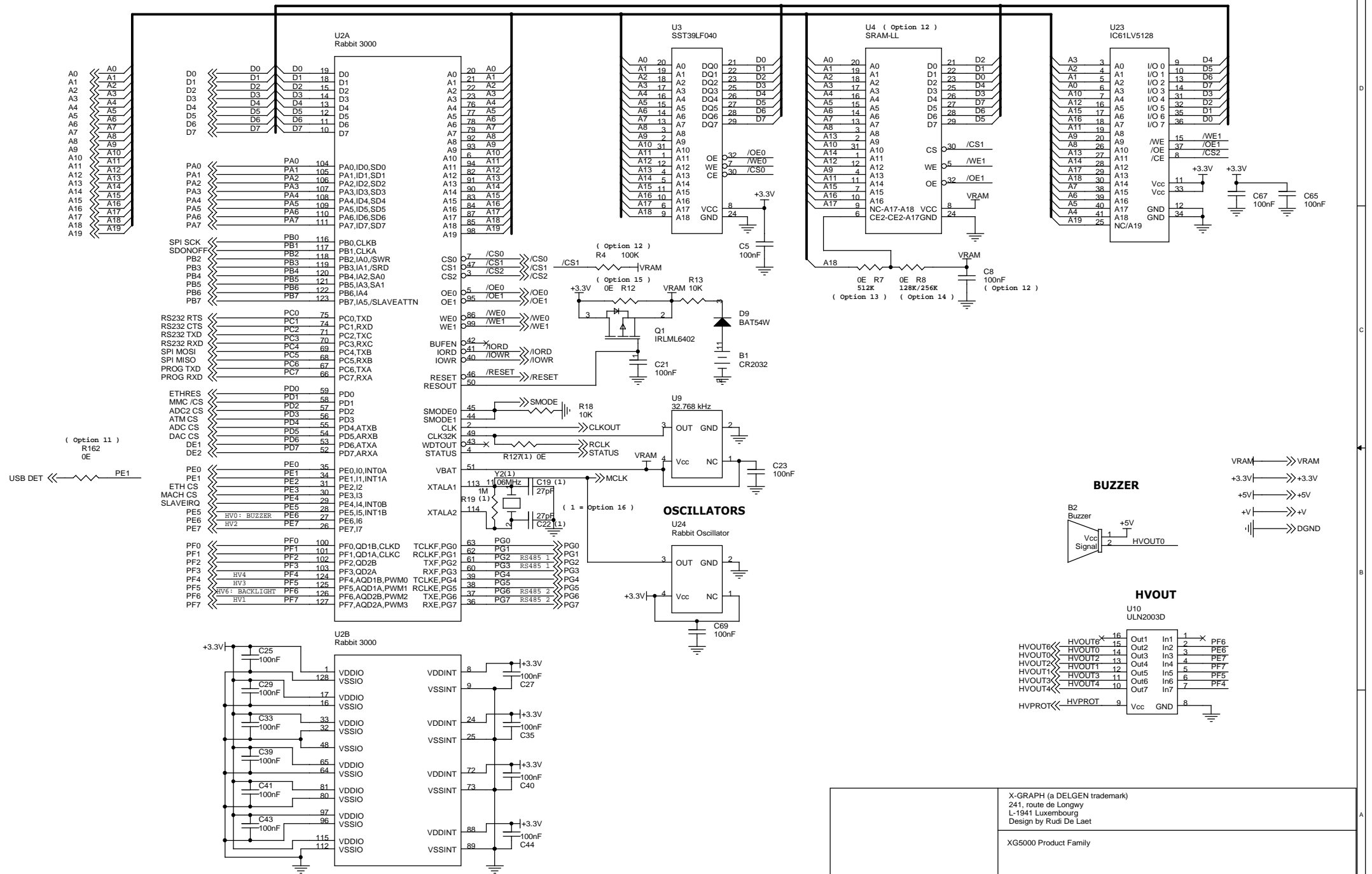

BUZZER

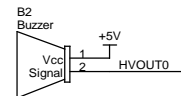

HVOUT

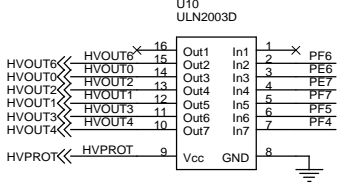

X-GRAPH (a DELGEN trademark) 241, route de Longwy L-1941 Luxembourg Design by Rudi De Laet			
XG5000 Product Family			
Size	CAGE Code	DWG NO	Rev
A3		XG5000-R7	1
Tuesday, May 24, 2011		Scale	Sheet
			5 of 7

+3.3V \rightarrow +3.3V
 +5V \rightarrow +5V
 +V \rightarrow +V
 | | \rightarrow DGND

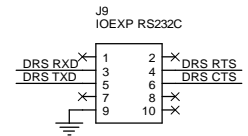
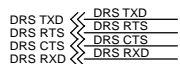

RS232C

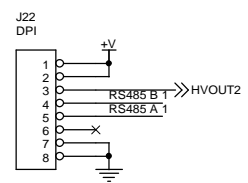
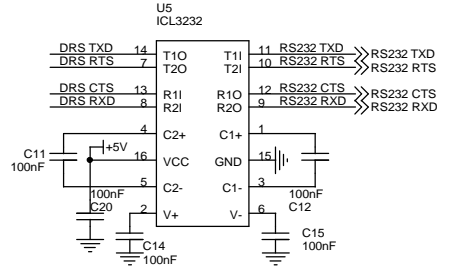

RS485

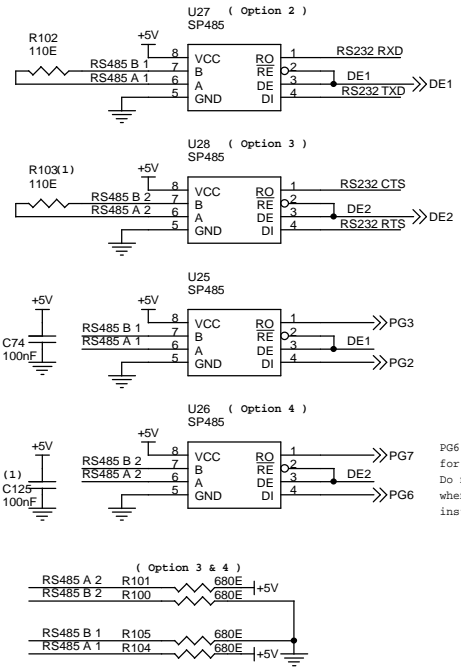

PG6/PG7 are reserved for the ZigBee module. Do not install Option 4 when a ZigBee is also installed.

ZigBee

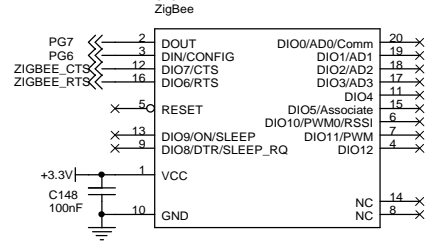

PROGRAMMING HEADER

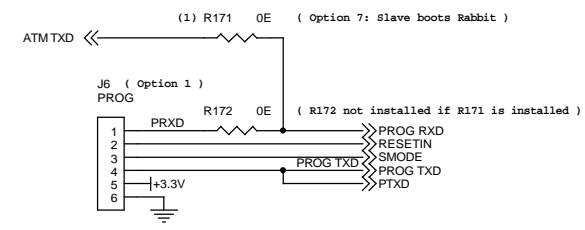

USB

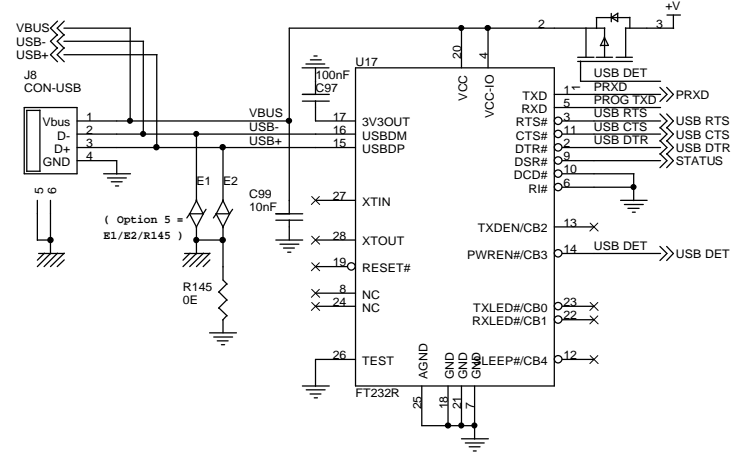

X-GRAPH (a DELGEN trademark) 241, route de Longwy L-1941 Luxembourg Design by Rudi De Laet		XG5000 Product Family	
Size A3	CAGE Code	DWG NO XG5000-R7	Rev 1
Tuesday, May 24, 2011	Scale	Sheet 6 of 7	

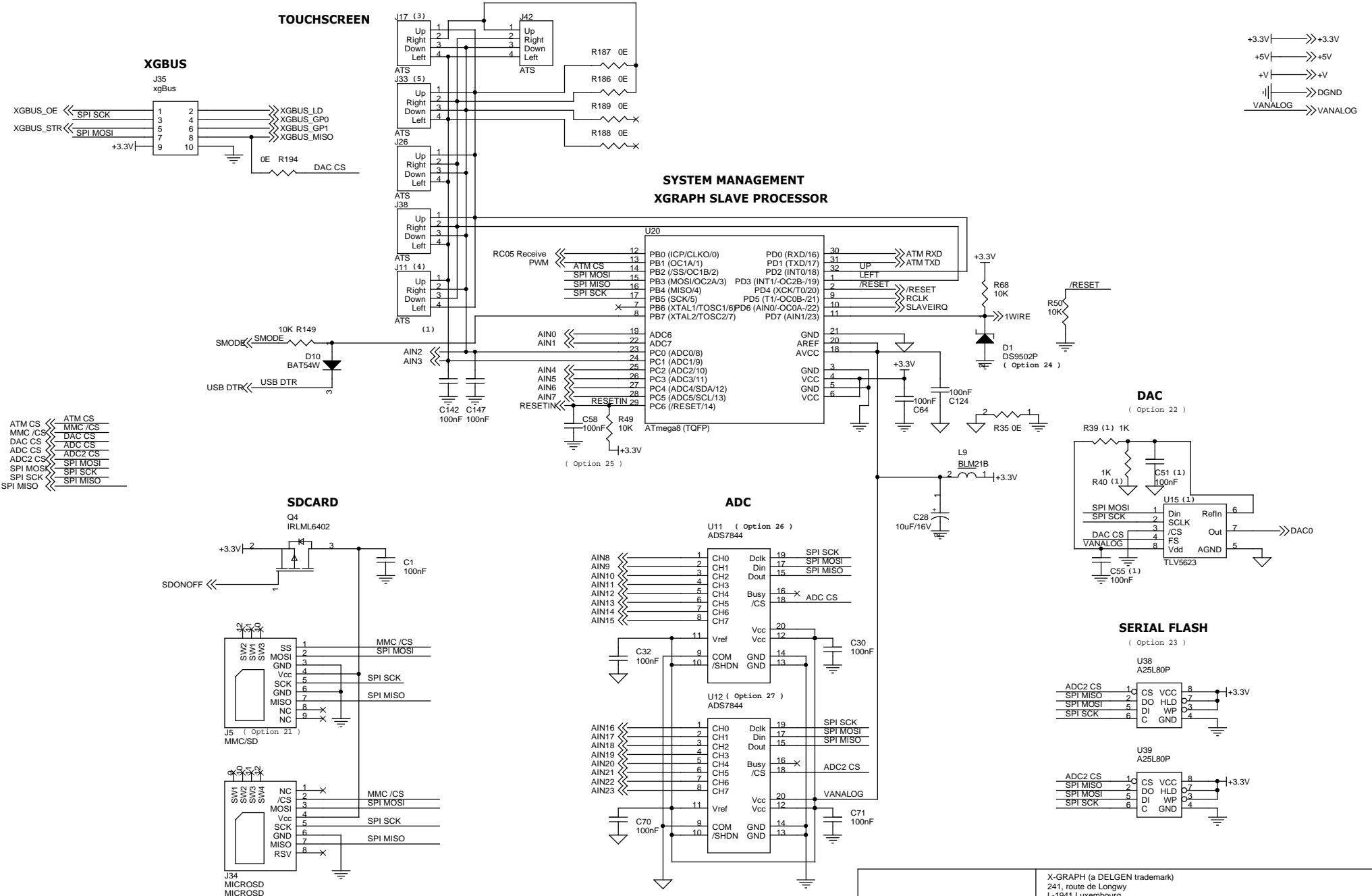

X-GRAPH (a DELGEN trademark) 241, route de Longwy L-1941 Luxembourg Design by Rudi De Laet			
XG5000 Product Family			
Size A3	CAGE Code	DWG NO XG5000-R7	Rev 1
Tuesday, May 24, 2011	Scale	Sheet 7 of 7	