

CPU

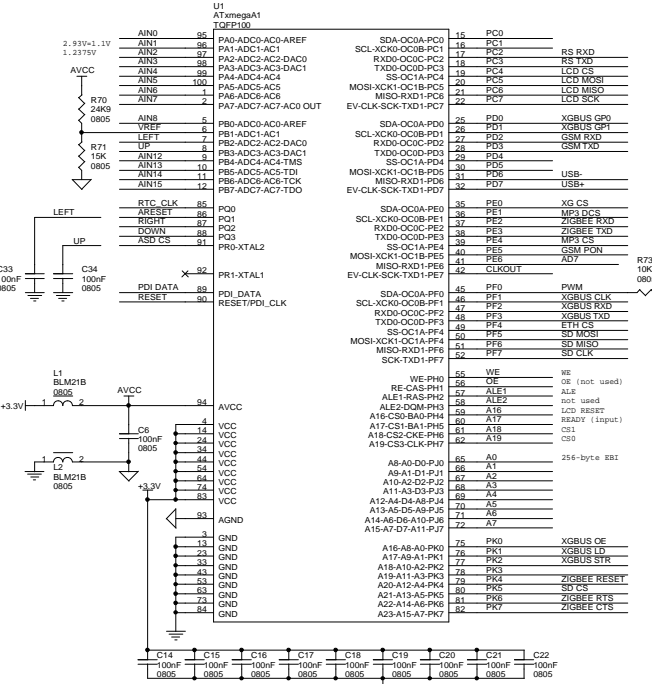

ZIGBEE

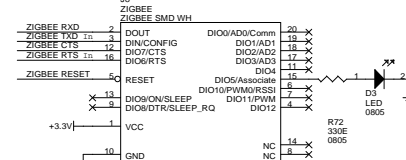

SDCARD

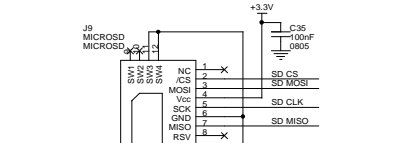

LCD CONTROLLER

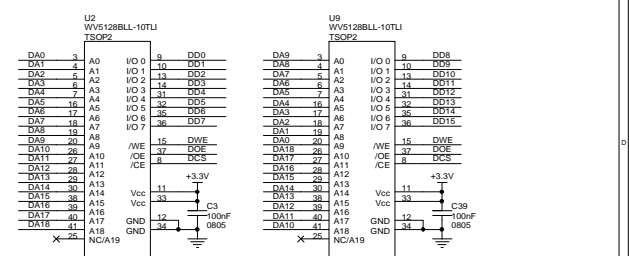
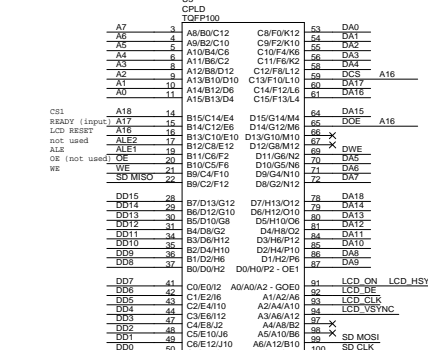

LCD CONNECTORS

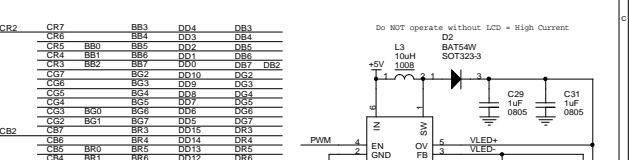

USB POWER SUPPLY

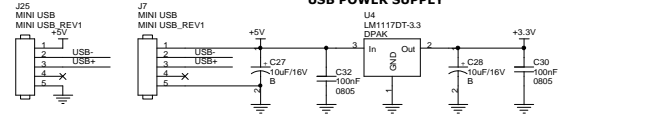

SDCARD

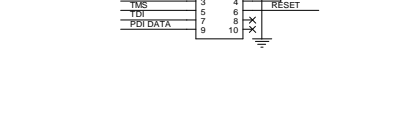

XG7100 EXPANSION HEADERS

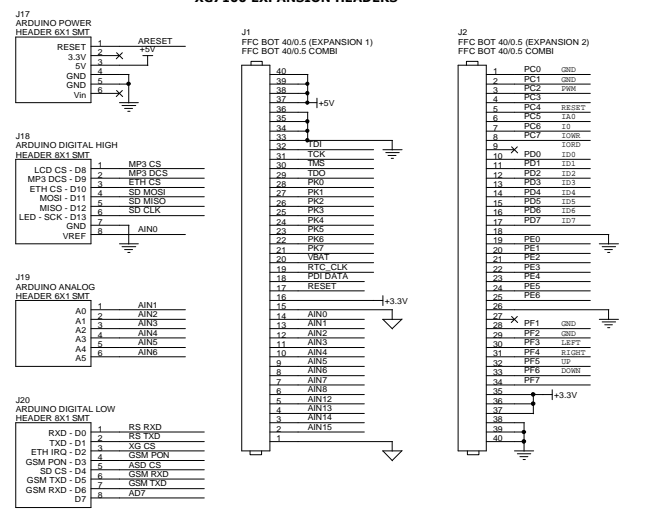

XG7000 EXPANSION HEADERS

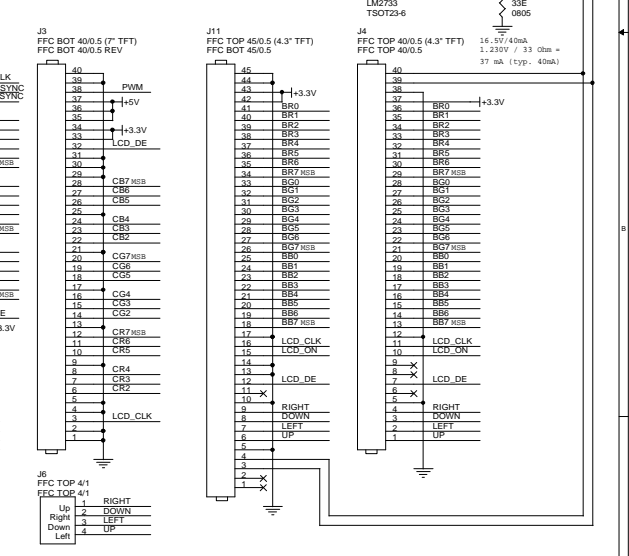
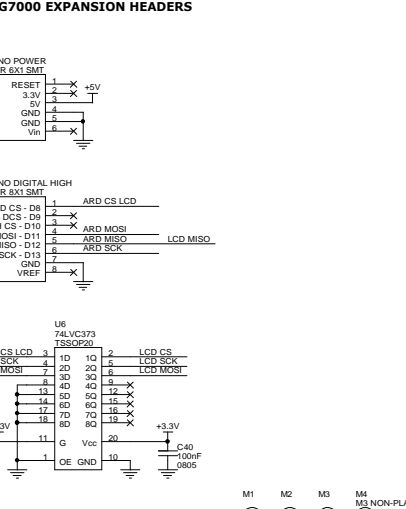

Table with 4 columns: Size, CAGE Code, DWG NO, Rev. Row 1: A2, 74LVC573 (TSOP29), XG7100 - XG8400, 1. Row 2: Scale, Sheet 1 of 1.

