

ARDUINO CONNECTOR

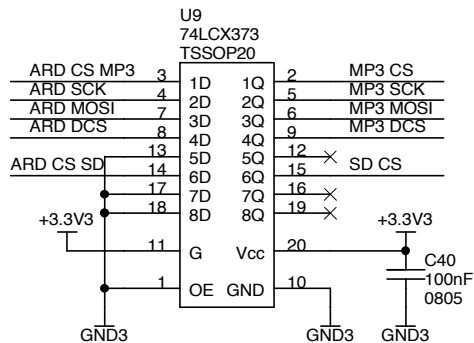

POWER SUPPLY

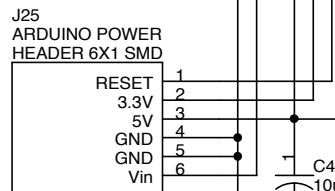
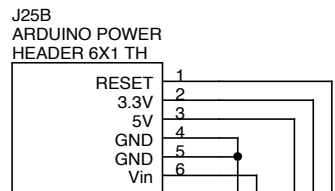
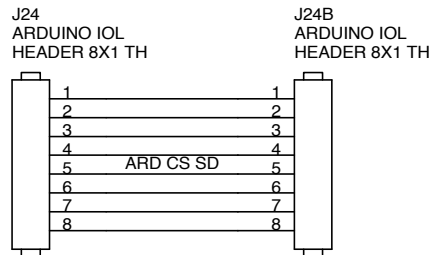
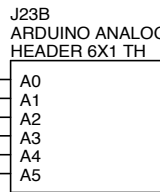
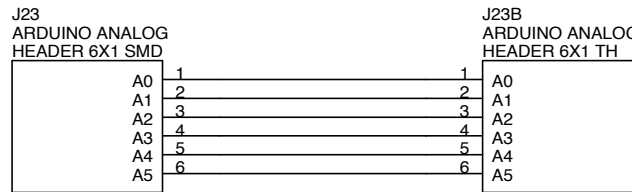
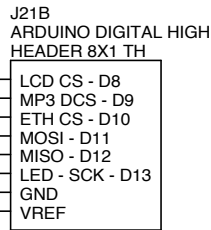
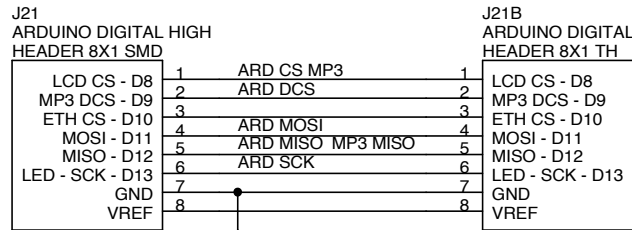
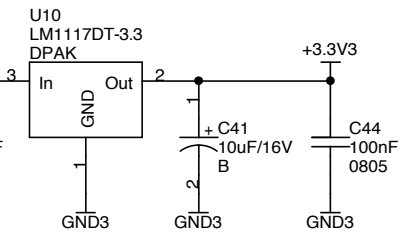

MP3

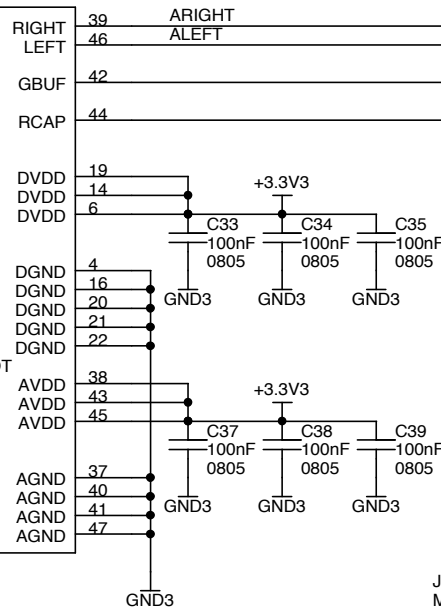
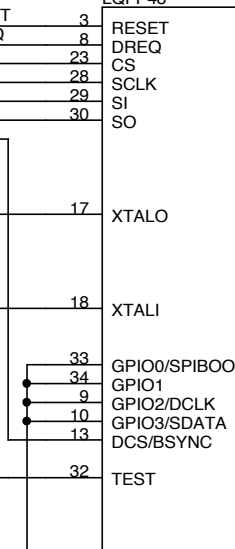
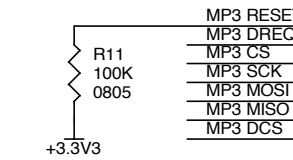

J27 MICROSD MICROSD

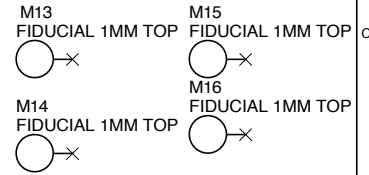
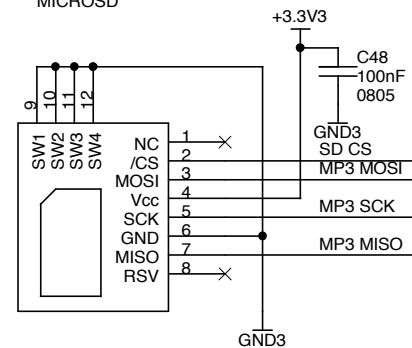

X-GRAPH (a DELCOMp trademark) Technologielaan 3 B-3001 Leuven			
X-Graph Arduino - XG8300 MP3			
Size A4	CAGE Code	DWG NO XG8300-R3	Rev 1
Monday, May 21, 2012		Scale	Sheet 4 of 5